

i =	3	4	5	7	10
nominal output torque (Nm)	30	40	35	26	16
max. acceleration torque (Nm)	45	62	56	44	24
emergency torque (Nm)	72	84	84	84	62

output shaft bearing: grooved ball bearing 2RS

- max. radial load: 1.450N bei n2=100 1/min Lh > 10.000h
- max. axial load: 1.550N bei n2=100 1/min Lh > 10.000h
- reference to shaft center at temp. = 30°C

straight-toothed planetary gearbox

backlash at output shaft: ≤ 8 arcmin

lifetime: > 30.000h

efficiency: by rated load 94% (depends on ratio)

lubrication: lifetime-lubrication

nominal output torque at n1 = 3.000 1/min

operating temperature: -20°C bis +90°C

motor mounting: M2 (stocked driving pinion)

- torque of clamping screw: 6Nm

operation mode: S1

operation ratio: cB1

protection system: IP54

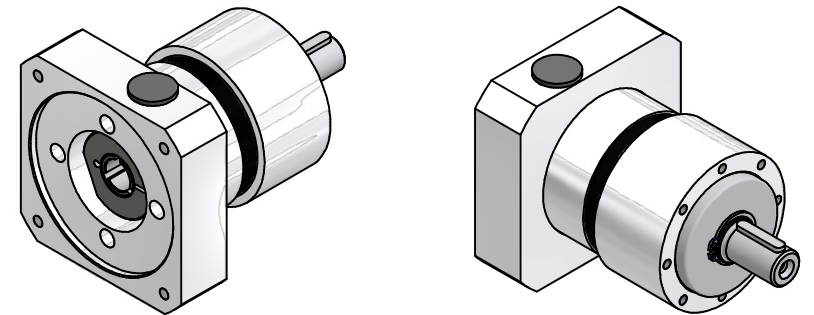

consider mounting instruction
subject to modifications

Allgemein- toleranzen ISO 2768-mK		Kanten ISO 13715	Maßstab 1:1 [Gewicht]
Verwendungsbereich		Datum 14.04.2020	Name Kanz
		Bearb. 13.05.2020	Name Kanz
		Freig.	
		Kd-Fr.	
EPL 70X/1			Blatt 2 / 2
400603100-1-E14-K-M468			A2
Zust.	Änderungen	Datum	Name
			Ursprung

