

40640444 / P064M039
 ZØ60G7-TkØ75-4xØ5,5-Vk70

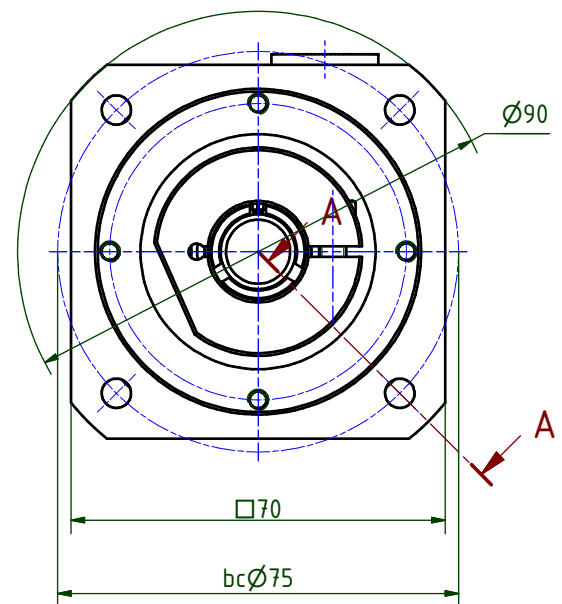
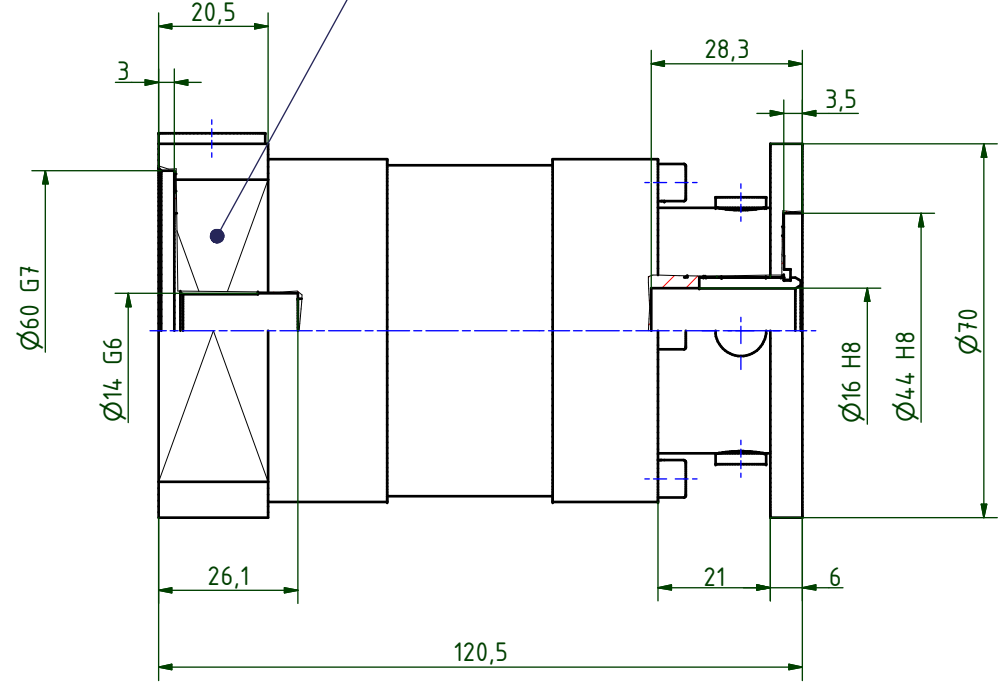
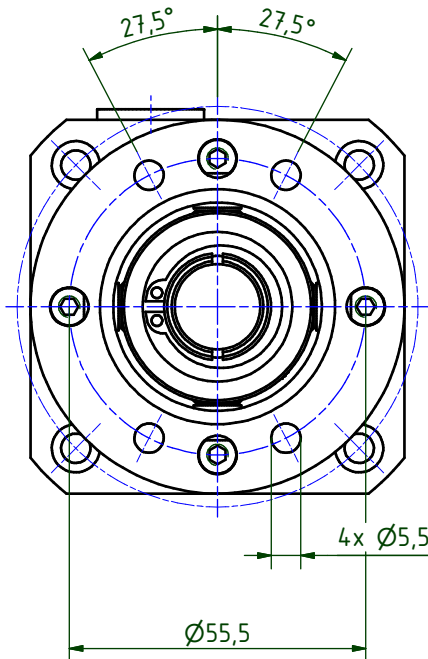

i =	12	16	20	25	35	40	50	70	100
nominal output torque (Nm)	36	42	42	44	44	42	44	42	18
max. acceleration torque (Nm)	45	52	52	55	55	52	55	52	28

output shaft bearing: deep groove ball bearings 2RS
 straight-toothed planetary gearbox
 backlash at output shaft: ≤ 14 arcmin
 lifetime: > 30.000h
 efficiency: by rated load 92% (depends on ratio)
 lubrication: lifetime-lubrication
 nominal output torque at n1 = 3.000 1/min
 operating temperature: -20°C bis +90°C
 motor mounting: M2 (stocked driving pinion)
 • torque of clamping screw: 6Nm
 operation mode: S1
 operation ratio: cB1
 protection system: IP54

consider mounting instruction
 subject to modifications

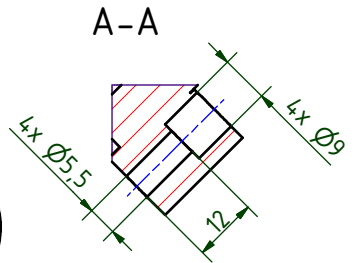
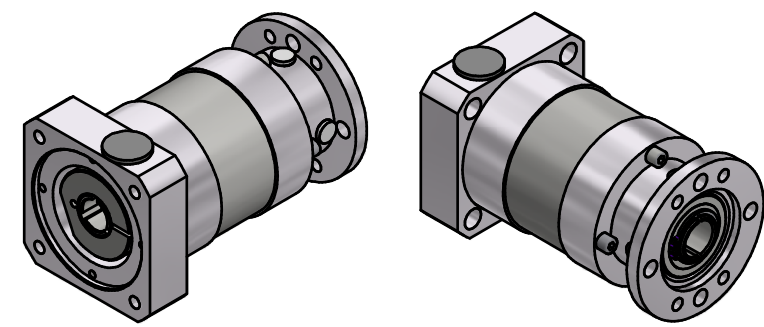

		Allgemein- toleranzen	Kanten ISO	Maßstab 1 : 1	(Gewicht)
		ISO 2768-mK	13715	Werkstoff, Halbzeug Allgemein	
Verwendungsbereich		Datum	Name	Rohteil-Nr.	
		Erst. 20.04.2022	Kanz	Modell- oder Gesenk-Nr.	
		Bearb. 20.04.2022	Kanz	EPL-H64/2	
		Freig.			
		Kd-Fr.			
		Eisele Antriebs-technik		40060954-2-E14-K-M444	Blatt 2 / 2
Zust.	Änderungen	Datum	Name	Ursprung	A3