

i =	3	4	5	7	10
nominal output torque (Nm)	30	40	35	26	16
max. acceleration torque (Nm)	48	62	50	44	24
emergency torque (Nm)	72	84	84	84	62

output shaft bearing: grooved ball bearing 2RS

- max. radial load: 600N bei n2=100 1/min Lh > 10.000h
- max. axial load: 1.200N bei n2=100 1/min Lh > 10.000h
- reference to shaft center at temp. = 30°C

straight-toothed planetary gearbox

backlash at output shaft: ≤ 8 arcmin

lifetime: > 30.000h

efficiency: by rated load 94% (depends on ratio)

lubrication: lifetime-lubrication

nominal output torque at n1 = 3.000 1/min

operating temperature: -20°C bis +90°C

motor mounting: M2 (stocked driving pinion)

- torque of clamping screw: 6Nm

operation mode: S1

operation ratio: cB1

protection system: IP65

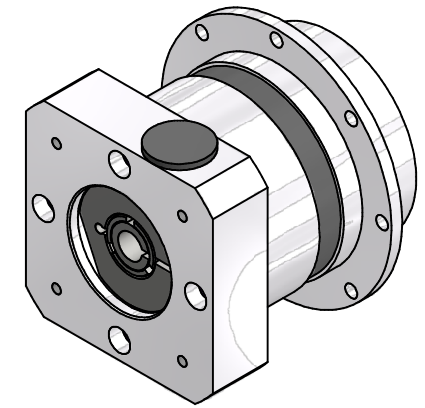
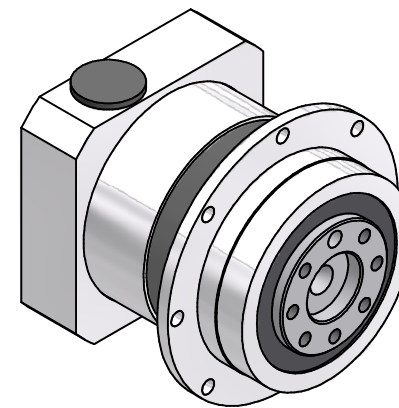

consider mounting instruction
subject to modifications

Verwendungsbereich		Allgemein- toleranzen ISO 2768-mK	Kanten ISO 13715	Maßstab 1:1 [Gewicht]
		Datum 28.02.2022	Name Kanz	EPLFE64/1
		Bearb. 28.02.2022	Kanz	
		Freig.		
		Kd-Fr.		
				46400300-1-E9-K-M405
				Blatt 2 / 2 A2
Zust.	Änderungen	Datum	Name	Ursprung