

i =	12	16	20	25	35	40	50	70	100
nominal output torque (Nm)	43	52	52	47	47	52	47	42	18
max. acceleration torque (Nm)	57	71	71	62	62	71	62	52	28
emergency torque (Nm)	72	84	84	84	84	84	84	84	62

output shaft bearing: grooved ball bearing 2RS

- max. radial load: 600N bei n2=100 1/min Lh > 10.000h
- max. axial load: 1.200N bei n2=100 1/min Lh > 10.000h
- reference to shaft center at temp. = 30°C

straight-toothed planetary gearbox

backlash at output shaft: ≤ 12 arcmin

lifetime: > 30.000h

efficiency: by rated load 92% (depends on ratio)

lubrication: lifetime-lubrication

nominal output torque at n1 = 3.000 1/min

operating temperature: -20°C bis +90°C

motor mounting: M2 (stocked driving pinion)

- torque of clamping screw: 6Nm

operation mode: S1

operation ratio: cB1

protection system: IP65

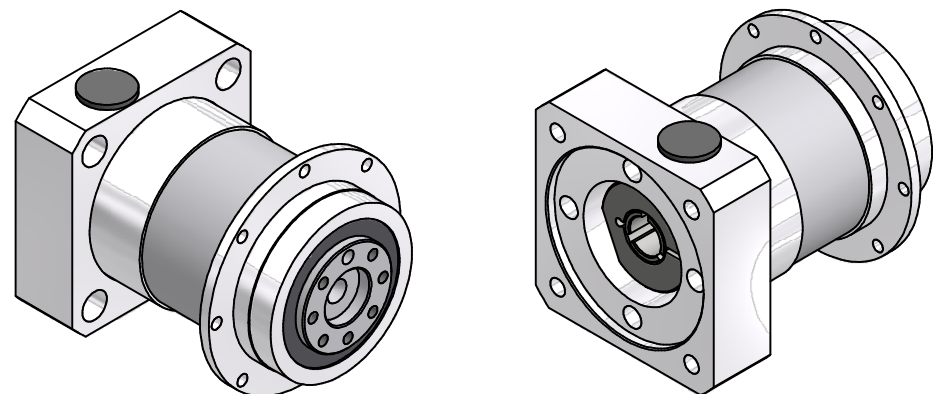

consider mounting instruction
subject to modifications

Allgemein- toleranzen ISO 2768-mK		Kanten ISO 13715	Maßstab 1:1 [Gewicht]
Verwendungsbereich		Werkstoff, Halbzeug Rohteil-Nr. Modell- oder Gesenk-Nr.	
Erst	Datum	Name	EPLFE64/2
Bearb.	22.02.2022	Kanz	
Freig.	22.02.2022	Kanz	
Kd-Fr.			
Zust.		46400301-2-E14-K-M402	
Änderungen		Datum Name Ursprung	
		Blatt 2 / 2 A2	

